

AUTOMATISK VINDUESÅBNER
AUTOMATIC WINDOW OPENER
AUTOMATISCHER FERNSTEROFFNER
DISPOSITIF D'OUVERTURE AUTOMATIQUE
AUTOMATIikka KATTOLUUKKUUN
APERTURA AUTOMATICA PER PRESE D'ARIA
AUTOMATISCHE RAAMOPENER
АВТОМАТИЧЕСКИЙ СТЕКЛОПОДЪЕМНИК

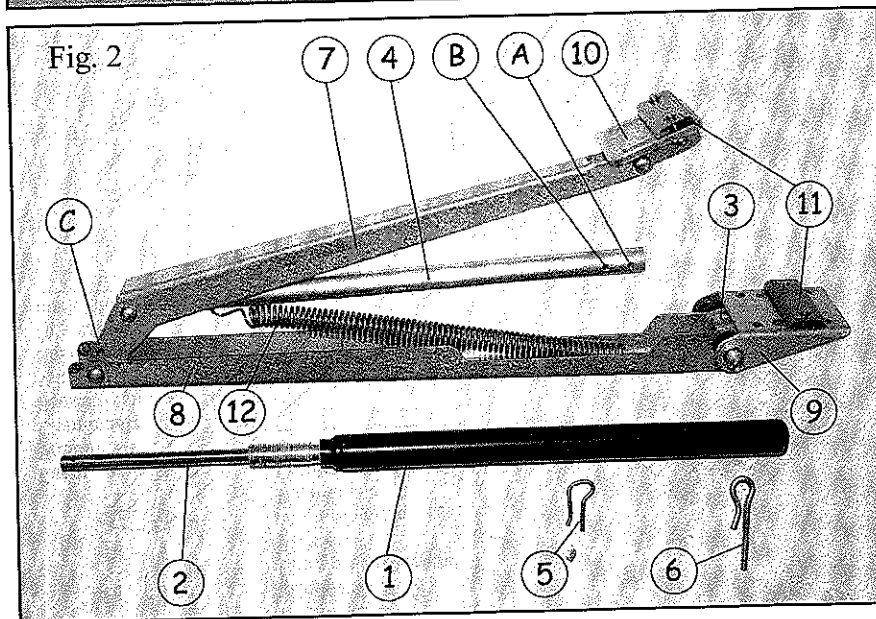
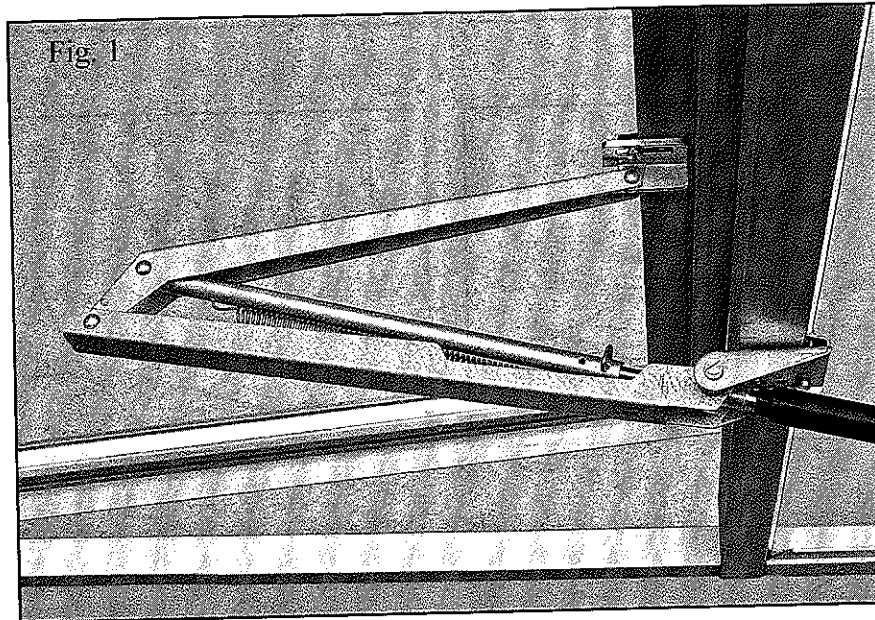

Notes:

1. Your automatic window opener is not suitable for use where temperatures will exceed 50°C/122°F.
2. Ensure that your greenhouse window is able to open and is not obstructed otherwise damage could occur.

Technical data:

- A. Maximum window opening approximately 45 cm/18".
- B. Maximum opening at 30°C/86°F depending on adjustment and load.
- C. Suitable for greenhouse vents weighing up to 7kg/15lb.
- D. Your automatic window opener can be adjusted to open at temperatures in the range 15°-25°C/ 60°-77°F.

Components:

See fig. 2.

1. Cylinder
2. Piston rod
3. Cylinder housing / threaded ring
4. Push-rod
5. Little hairpin
6. Big hairpin (only for special purpose)
7. Arm K
8. Arm L
9. Sill bracket
10. Window bracket
11. Clamps
12. Pullback spring

Maintenance:

Lubricate all movable parts with a light oil after fitting, each Spring and as required during the Summer. Apply petroleum jelly to the cylinder thread occasionally.

Winter storage:

It is recommended that your window opener - or at least the cylinder - is removed from your greenhouse for the Winter. Store it in a dry place and do not forget to lubricate particularly the piston rod before remounting in the Spring. Check that the piston rod moves smoothly.

Guarantee:

Your automatic window opener is guaranteed for a periode of 1 year from the date of purchase provided that it has been fitted and maintained in accordance with the instructions.

Fitting instructions:

1. Check that the greenhouse window opens freely and is not obstructed.
Remove existing casement stays and arms from the window and frame.
2. Fit the opener onto the window and its outer frame.
 - 2a. On most greenhouses made out of aluminium Fitting is done using the enclosed clamps (11) - se Fig.3. Start fittingFit one clamp loosely onto the windowbracket (10) of the opener using the enclosed screws. Choose the most suitable holes on the sillbracket of the opener and fit the second clamp onto this. Make sure that

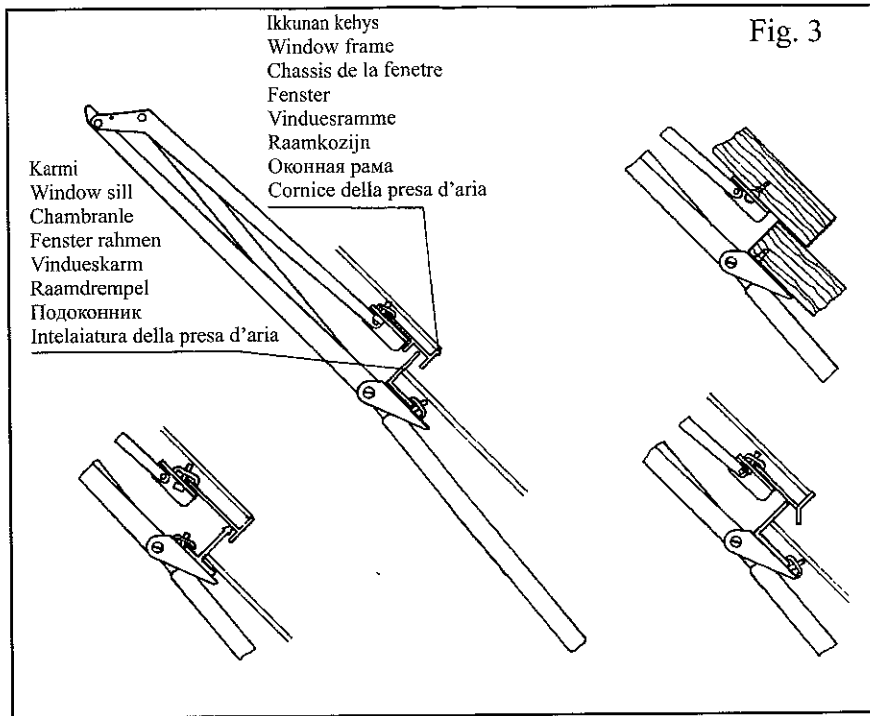

Fig. 3

the upper edge of the sillbracket is as close as possible to the edge of the windowsill.

- 2b. On For greenhouses made out of wood, get some screws for wood – and then follow our instructions mentioned outlined under pos. 3-4-5-6
- 2c. On aluminium-greenhouses where our clamps do not fit, read the manual supplied by the greenhouse manufacturer – and then follow our instructions mentioned under pos. 3-4-5-6
3. Insert the piston rod (2) on the cylinder (1) into the push-rod (4), and align the hole at the end of the piston-rod with Hole A in the push-rod, and lock it by inserting the small hairpin (5) – see Fig.5.
4. Tighten the sillbracket of the opener onto the centre of the windowsill – see Fig.6.
5. Tighten the windowbracket onto the windowframe right above the sillbracket. The window must remain closed during this operation.
6. ONow open the window just enough for to allowing the thread on the cylinder to catch the thread inside the cylinder housing (3). Then wind the cylinder on until equally much of the cylinders thread is visible on either side of the cylinder housing – see Fig.7.
7. Check if the window can open freely as much as the opener allows it to. If not, the opening width of the window opener should be reduced.

REDUCING THE OPENING WIDTH

1. The opening width can be obstructed at a width of 32 cm (appr. 12½") by inserting the big hairpin into hole C on the arm called K (7) and locking the push-rod to the piston-rod using hole B.
2. By assembling the piston-rod to the push-rod in hole B, a small reduction of the opening width is gained, at the same time as the start-opening temperature is delayed. If the thread of the cylinder has just been entered a few rounds into the cylinder housing – and the locking is made using hole B – the opener will start its begin opening at appr. 28°C.
3. Choose the most suitable pair of holes and loosely fit the other clamp to the frame bracket (9).

Adjustment:

In order that your vent control should start opening the window at a different temperature, adjustment can be made by turning the cylinder:

Clockwise to achieve an earlier/higher opening.

Anticlockwise to achieve a later/lower opening.

One complete turn corresponds to approximately 0,5°C/1°F.

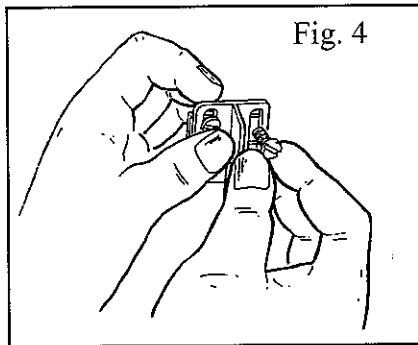

Fig. 4

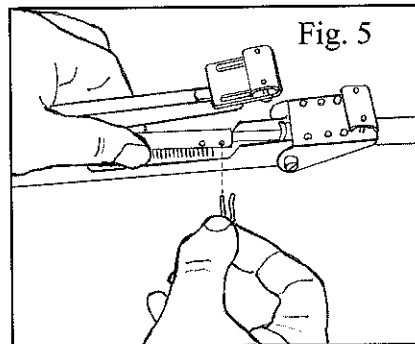

Fig. 5

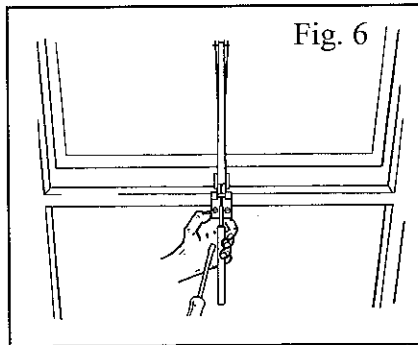

Fig. 6

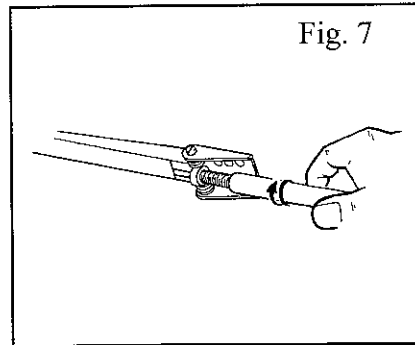

Fig. 7