















1-Tier Heavy Duty Staging Instructions

Important.

Please read the instructions completely before starting assembly.



Parts List

Profile	Description	Size	No.	Code
	Leg	760mm	4	K1-2
	Long Horizontal Slat Support	1200mm	2	K2-2
	Short Horizontal Strut	517mm	2	K3-1
	Long Horizontal Strut	1200mm	2	K3-2
	Slat	518mm	16	K4-3
	Corner Brace - short	161mm	4	K5-1
	Corner Brace - long	664mm	4	K3-3
	Bolts	10mm	16	M610
	Nuts		16	M6-1
	Self-tapping Screw	No6 x 6mm	8	66
	Self-tapping Screw	16mm	4	616
	Self-tapping Screw	19mm	32	619

Section 1

Tools:

- Flat and crosshead screwdrivers
- 10mm Spanner

Section 2

Before you start:

Identify and lay out the parts and fittings.

Figs. A & B

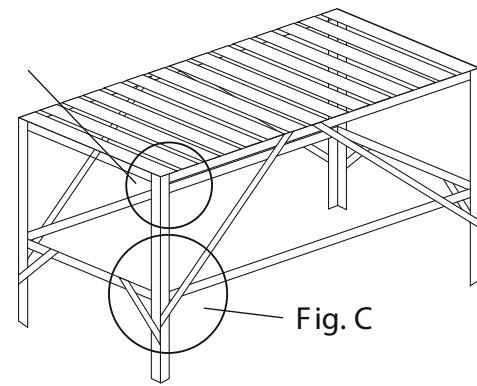

Section 3

Assembly:

- Screw the slats (K4-3) to the supports (K2-2) using the self-tapping screws (619), spacing evenly (32mm approx), or as required.
- Screw the legs (K1-2) to the ends of the slat supports (K2-2) using the self-tapping screws (616).

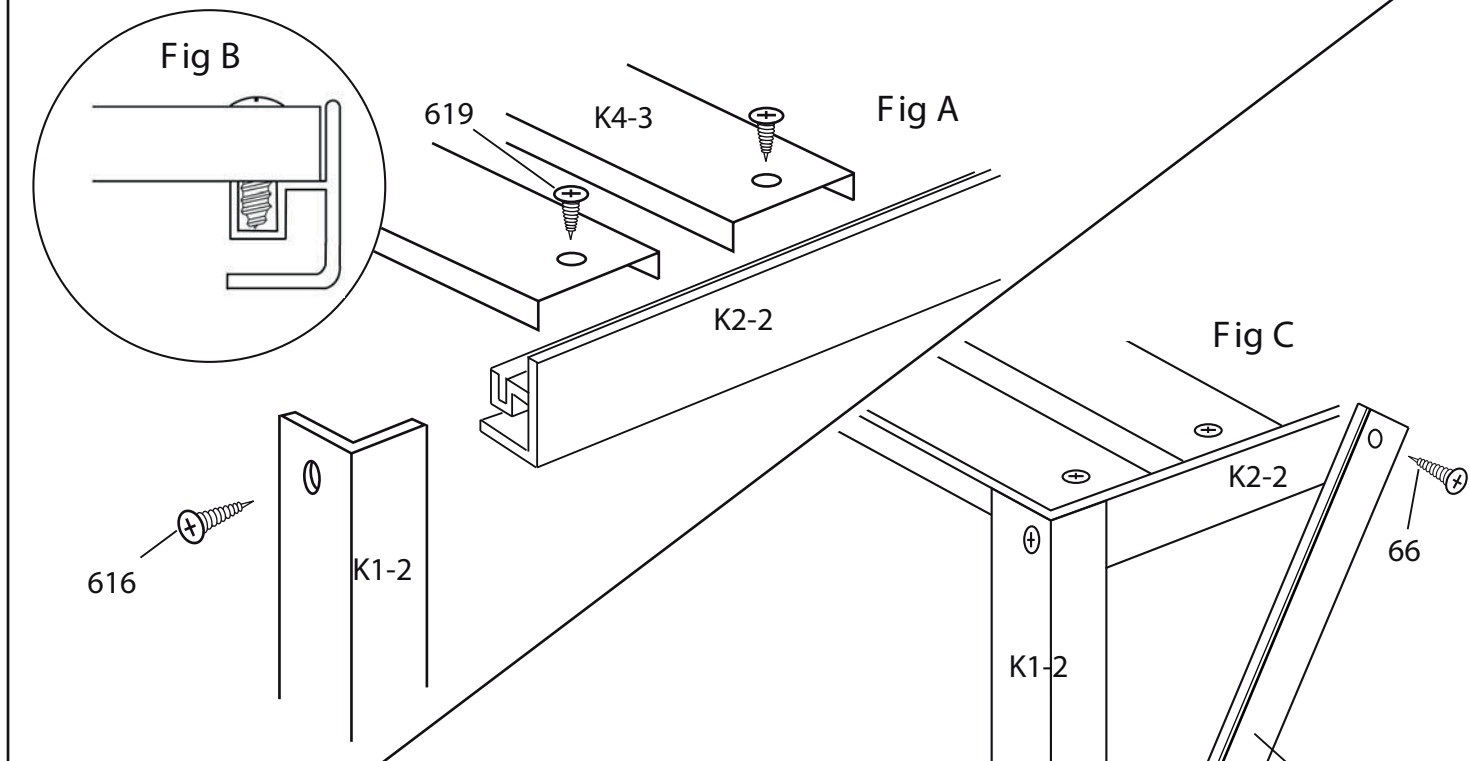

Section 4 (Fig C)

- Bolt the two long horizontal struts (K3-2) between the legs (K1-2) at the front and back of the staging.
- Bolt the two short struts (K3-1) between the legs (K1-2) at both ends of the staging
- Add the four long braces (K5-2) between the legs (K1-2) and the slat supports (K2-2) at the front and back of the staging
- Add the four short braces (K5-1) between the legs (K1-2) and the short struts (K3-1) at both ends of the staging
- Ensure all screws and nuts are tightened.

